

Technical Data Sheet

ENGINEERING
TOMORROW



Compressor model **NPT16RA**
Voltage **220-240V 50Hz ~1**
Refrigerant **R290**

APPLICATION

COMPRESSOR

MOTOR

Application	High Back Pressure	Displacement	16,10 cm ³	Nominal Power	2/3 hp
Refrigerant	R290	Diameter	31,19 mm	Voltage/Frequency	220-240V 50Hz
Evaporating Temp.	-15,0 °C to 10,0 °C	Stroke	21,13 mm	Voltage range	198-255 V
Expansion	Capillar/Valve	Net Weight	12,34 Kg	Type	CSR
Comp. Cooling	Fan cooled	Oil type	ISO VG 32 ESTER	Phase number	1 PH
Max. ambient temp.	43,0 °C	Oil charge	400 cm ³	Locked Rotor Amps (LRA)	21,00 A
				Max. Cont. Current (MCC)	5,90 A
				Main W. resist. at 25°C	4,50 Ω
				Start W. resist. at 25°C	5,75 Ω

NOMINAL PERFORMANCE

	ASHRAE	CECOMAF
Cooling Capacity	1.986 kCal/h	1.911 W
COP	2,55 W/W	2,18 W/W
EER	2,19 kCal/Wh	1,88 kCal/Wh
Input Power	906 W	878 W
Current	4,17 A	4,04 A

APPROVALS



TEST CYCLE CONDITIONS

	ASHRAE HBP (D)	CECOMAF HBP (C)
Evaporating temp. (T _e)	7,2 °C	5,0 °C
Condensing temp. (T _c)	55,0 °C	55,0 °C
Liquid temp. (T _{liq.})	46,0 °C	55,0 °C
Ambient temp. (T _{amb.})	35,0 °C	32,0 °C
Suction temp. (T _{suction})	35,0 °C	32,0 °C
Voltage/Frequency	220 V 50 Hz	220 V 50 Hz

ELECTRICAL COMPONENTS

Starting capacitor	72- 88 µF 330 V			
Run capacitor	25 µF 420 V			
Relay	Option 1	Option 2		
Reference	2014 166. + NTC15Ω	QLZ-11.0A+NTC15		
Pick-Up	11,00 A	11,00 A		
Drop-Out	9,35 A	9,35 A		
Protector	Option 1			
Reference	T0348			
Current	15,40 A			
Time check	7,5-14 seg			
Disc temp. (Open/Close)	105,00 / 52,00 °C			

This product is approved for R290 and R600a regarding explosion safety according to standard EN 60335-1 and EN 60335-2-34

Made by Huayi for Danfoss

Technical Data Sheet NPT16RA

Printed on 03/11/20

1/4

Technical Data Sheet

ENGINEERING
TOMORROW



ASHRAE

Tc	Te	Cooling Capacity	Consumption	Current	COP	EER
°C	°C	kCal/h	W	A	W/W	kCal/Wh
40	-15	926	553	2,56	1,95	1,68
40	-10	1.099	573	2,65	2,23	1,92
40	-5	1.332	602	2,78	2,57	2,21
40	0	1.624	641	2,95	2,95	2,54
40	5	1.976	688	3,17	3,34	2,87
40	7,2	2.150	711	3,27	3,52	3,02
40	10	2.387	743	3,42	3,73	3,21

45	-15	887	583	2,70	1,77	1,52
45	-10	1.057	611	2,82	2,01	1,73
45	-5	1.286	648	2,99	2,31	1,98
45	0	1.575	694	3,20	2,64	2,27
45	5	1.923	749	3,45	2,99	2,57
45	7,2	2.095	776	3,57	3,14	2,70
45	10	2.330	813	3,74	3,34	2,87

50	-15	848	614	2,83	1,61	1,38
50	-10	1.014	650	3,00	1,82	1,56
50	-5	1.240	694	3,20	2,08	1,79
50	0	1.525	748	3,44	2,37	2,04
50	5	1.870	811	3,73	2,68	2,31
50	7,2	2.041	841	3,87	2,82	2,43
50	10	2.274	882	4,06	3,00	2,58

55	-15	809	644	2,97	1,46	1,26
55	-10	972	688	3,17	1,64	1,41
55	-5	1.194	741	3,41	1,88	1,61
55	0	1.476	802	3,69	2,14	1,84
55	5	1.817	872	4,01	2,42	2,08
55	7,2	1.986	906	4,17	2,55	2,19
55	10	2.218	951	4,38	2,71	2,33

60	-15	770	675	3,11	1,33	1,14
60	-10	929	726	3,34	1,49	1,28
60	-5	1.148	787	3,62	1,70	1,46
60	0	1.427	856	3,94	1,94	1,67
60	5	1.764	934	4,30	2,20	1,89
60	7,2	1.932	971	4,47	2,31	1,99
60	10	2.161	1.021	4,71	2,46	2,12

CECOMAF

Tc	Te	Cooling Capacity	Consumption	Current	COP	EER
°C	°C	W	W	A	W/W	kCal/Wh
40	-15	996	556	2,57	1,79	1,55
40	-10	1.186	576	2,67	2,06	1,78
40	-5	1.437	606	2,80	2,37	2,05
40	0	1.751	645	2,97	2,72	2,35
40	5	2.126	692	3,19	3,07	2,65
40	7,2	2.311	716	3,30	3,23	2,79
40	10	2.564	748	3,44	3,43	2,96

45	-15	948	586	2,71	1,62	1,40
45	-10	1.132	615	2,84	1,84	1,59
45	-5	1.377	652	3,01	2,11	1,82
45	0	1.685	699	3,22	2,41	2,08
45	5	2.055	754	3,47	2,72	2,35
45	7,2	2.237	781	3,59	2,86	2,47
45	10	2.486	818	3,76	3,04	2,63

50	-15	900	617	2,85	1,46	1,26
50	-10	1.078	653	3,01	1,65	1,43
50	-5	1.317	699	3,22	1,89	1,63
50	0	1.619	753	3,46	2,15	1,86
50	5	1.983	816	3,75	2,43	2,10
50	7,2	2.163	847	3,90	2,55	2,21
50	10	2.409	888	4,09	2,71	2,34

55	-15	853	648	2,99	1,32	1,14
55	-10	1.024	692	3,19	1,48	1,28
55	-5	1.258	745	3,43	1,69	1,46
55	0	1.553	807	3,71	1,92	1,66
55	5	1.911	878	4,04	2,18	1,88
55	7,2	2.088	912	4,20	2,29	1,98
55	10	2.331	958	4,41	2,43	2,10

60	-15	805	678	3,13	1,19	1,02
60	-10	970	730	3,36	1,33	1,15
60	-5	1.198	791	3,64	1,51	1,31
60	0	1.488	861	3,96	1,73	1,49
60	5	1.839	940	4,33	1,96	1,69
60	7,2	2.014	977	4,50	2,06	1,78
60	10	2.253	1.028	4,74	2,19	1,89

EN12900

X	Cooling Capacity (W)	Consumption (W)	Current (A)	Mass Flow (kg/h)
1	2.297,2791660969	216,2103901745	0,9931419043	17,417301257363
2	79,4934187367	-3,9153559850	-0,0199059211	0,6729829612104
3	-14,3006889083	11,1374842942	0,0512720047	0,067037262863239
4	1,2184514098	0,1901225521	0,0009105294	0,019061800196913
5	-0,2854647892	0,3236806590	0,0015266231	0,0048488256372685

Equation	$x_1 + x_2Te + x_3Tc + x_4Te^2 + x_5TeTc$
----------	---

COMPRESSOR DIMENSIONS

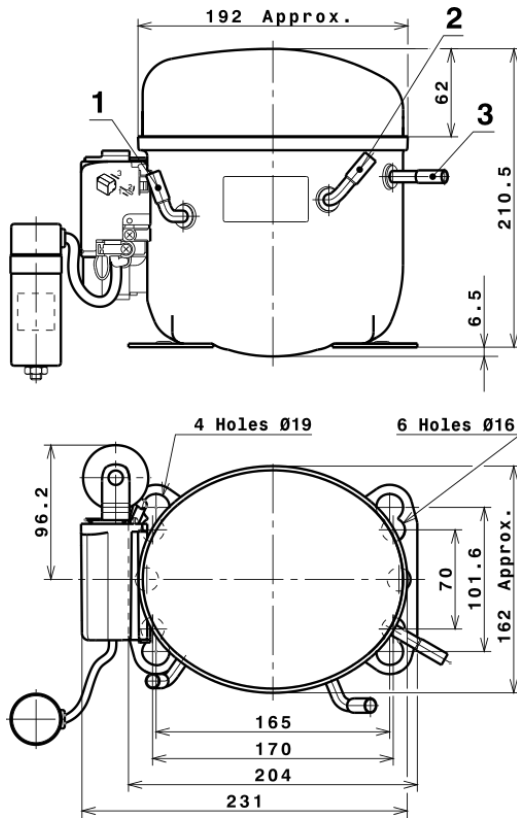

DESIGNATION INTERNAL DIAM.

DESIGNATION	INTERNAL DIAM.
1 Suction	8,1 mm
2 Service	8,1 mm
3 Discharge	6,5 mm

WIRING DIAGRAMS AND ELECTRICAL ASSEMBLY

CSR CONNECTION (CURRENT RELAY + NTC) (L, P ranges)

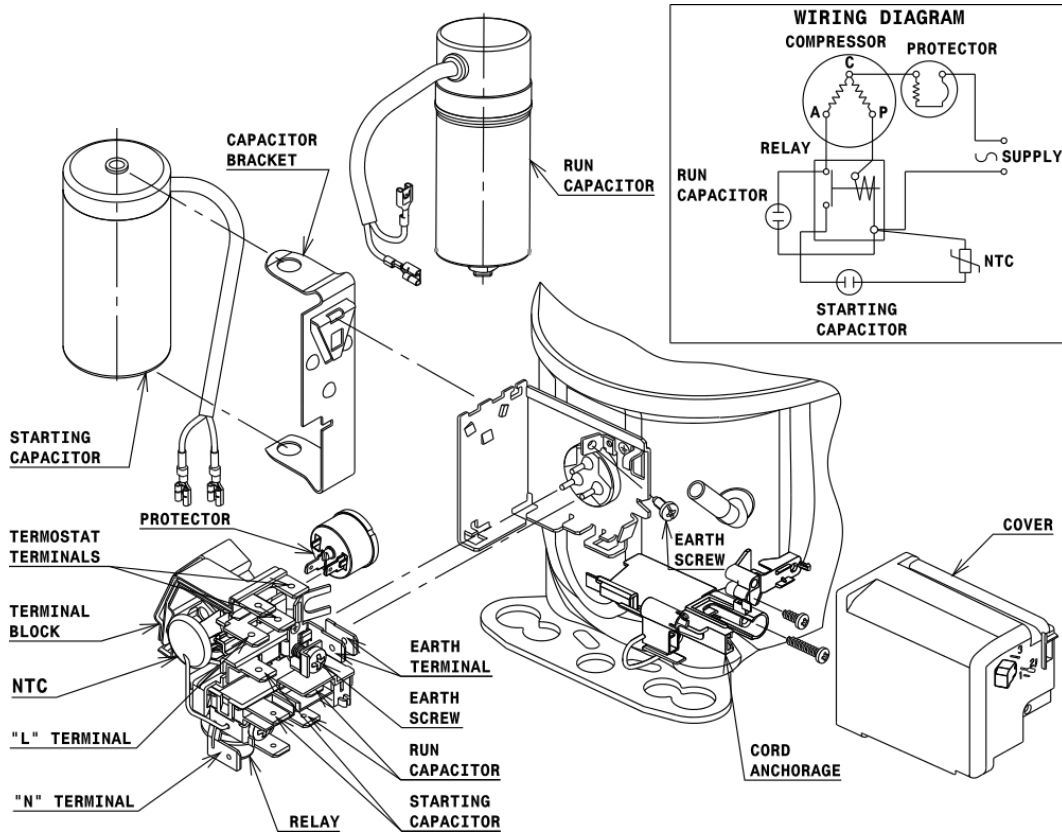

FIXINGS

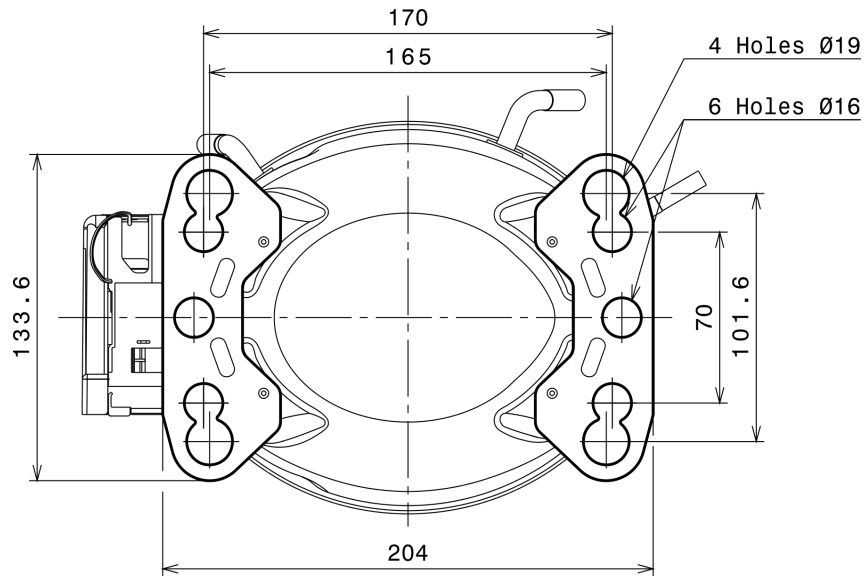

SILENT BLOCKS (MOUNTING ACCESSORIES)

STANDARD

Ø16 holes (170x70 net)

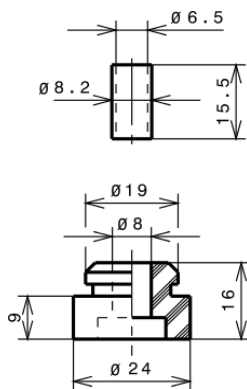

AMERICAN FEET

Ø19 holes (165x101.6 net)

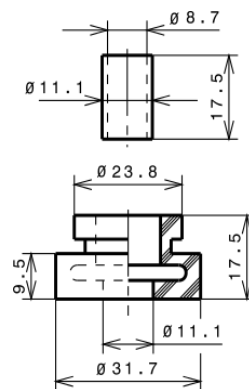

SNAP-ON

Ø16 holes (170x70 net)

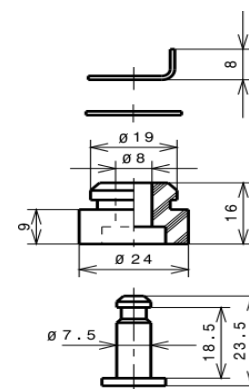

SOA

SOA R290 HBP

