

Technical Data Sheet

ENGINEERING
TOMORROW



Compressor model **NUY90RAa**
 Voltage **220-240V 50Hz ~1**
 Refrigerant **R290**
 Compressor status

APPLICATION

COMPRESSOR

MOTOR

Application	High Back Pressure	Displacement	8,90 cm ³	Voltage/Frequency	220-240V 50Hz
Refrigerant	R290	Diameter	24,30 mm	Voltage range	198-255 V
Evaporating Temp.	-15,0 °C to 10,0 °C	Stroke	19,00 mm	Type	CSIR
Expansion	Capillar/Valve	Net Weight	9,85 Kg	Phase number	1 PH
Comp. Cooling	Fan cooled	Oil type	ISO VG 46 ESTER	Main W. resist. at 25°C	6,22 Ω
Max. ambient temp.	43,0 °C	Oil charge	200 cm ³	Start W. resist. at 25°C	12,34 Ω
		HP	3/8 hp		

NOMINAL PERFORMANCE

	ASHRAE	CECOMAF
Cooling Capacity	1.063 kCal/h	1.038 W
COP	2,47 W/W	2,11 W/W
EER	2,12 kCal/Wh	1,82 kCal/Wh
Input Power	501 W	493 W
Current	3,04 A	3,01 A

APPROVALS



TEST CYCLE CONDITIONS

	ASHRAE HBP (D)	CECOMAF HBP (C)
Evaporating temp. (T _e)	7,2 °C	5,0 °C
Condensing temp. (T _c)	55,0 °C	55,0 °C
Liquid temp. (T _{liq.})	46,0 °C	55,0 °C
Ambient temp. (T _{amb.})	35,0 °C	32,0 °C
Suction temp. (T _{suction})	35,0 °C	32,0 °C
Voltage/Frequency	220 V 50 Hz	220 V 50 Hz

ELECTRICAL COMPONENTS

Starting capacitor	60-61 µF 330 V			
Relay	Option 1	Option 2		
Reference	2014 149.	QLZ-7.8A		
Pick-Up	7,80 A	7,80 A		
Drop-Out	6,65 A	6,65 A		
Protector	Option 1			
Reference	B110-105			
Current	11,00 A			
Time check	7,5-16 seg			
Disc temp. (Open/Close)	105,00 / 52,00 °C			

This product is approved for R290 and R600a regarding explosion safety according to standard EN 60335-1 and EN 60335-2-34

ASHRAE

Tc	Te	Cooling Capacity	Consumption	Current	COP	EER
°C	°C	kCal/h	W	A	W/W	kCal/Wh
40	-15	570	332	2,49	2,00	1,72
40	-10	690	352	2,55	2,28	1,96
40	-5	828	371	2,61	2,60	2,23
40	0	985	388	2,66	2,95	2,54
40	5	1.159	403	2,71	3,34	2,87
40	7,2	1.242	410	2,72	3,53	3,03
40	10	1.352	417	2,75	3,77	3,24

45	-15	533	344	2,53	1,80	1,55
45	-10	648	369	2,60	2,04	1,76
45	-5	781	392	2,67	2,32	2,00
45	0	932	413	2,73	2,63	2,26
45	5	1.102	432	2,80	2,97	2,55
45	7,2	1.182	440	2,82	3,12	2,69
45	10	1.289	450	2,86	3,33	2,87

50	-15	496	357	2,56	1,62	1,39
50	-10	606	385	2,65	1,83	1,57
50	-5	734	412	2,73	2,07	1,78
50	0	880	437	2,82	2,34	2,01
50	5	1.044	461	2,90	2,64	2,27
50	7,2	1.123	471	2,93	2,77	2,39
50	10	1.227	482	2,97	2,96	2,54

55	-15	459	369	2,60	1,45	1,24
55	-10	564	402	2,70	1,63	1,40
55	-5	687	433	2,80	1,85	1,59
55	0	828	462	2,90	2,08	1,79
55	5	987	489	3,00	2,35	2,02
55	7,2	1.063	501	3,04	2,47	2,12
55	10	1.165	515	3,09	2,63	2,26

60	-15	422	382	2,64	1,29	1,11
60	-10	522	418	2,75	1,45	1,25
60	-5	640	453	2,87	1,64	1,41
60	0	776	487	2,99	1,85	1,59
60	5	930	518	3,10	2,09	1,79
60	7,2	1.004	532	3,16	2,20	1,89
60	10	1.102	548	3,22	2,34	2,01

CECOMAF

Tc	Te	Cooling Capacity	Consumption	Current	COP	EER
°C	°C	W	W	A	W/W	kCal/Wh
40	-15	613	333	2,50	1,84	1,59
40	-10	743	354	2,56	2,10	1,81
40	-5	892	373	2,61	2,39	2,07
40	0	1.060	390	2,66	2,71	2,35
40	5	1.246	406	2,71	3,07	2,65
40	7,2	1.334	412	2,73	3,24	2,80
40	10	1.452	420	2,76	3,46	2,99

45	-15	570	346	2,53	1,65	1,42
45	-10	693	371	2,61	1,87	1,62
45	-5	836	394	2,68	2,12	1,83
45	0	997	415	2,74	2,40	2,07
45	5	1.177	435	2,81	2,71	2,34
45	7,2	1.262	443	2,83	2,85	2,46
45	10	1.376	453	2,87	3,04	2,63

50	-15	527	359	2,57	1,47	1,27
50	-10	644	387	2,66	1,66	1,44
50	-5	780	415	2,74	1,88	1,62
50	0	934	440	2,82	2,12	1,83
50	5	1.108	464	2,91	2,39	2,06
50	7,2	1.190	474	2,94	2,51	2,17
50	10	1.300	486	2,98	2,68	2,31

55	-15	484	371	2,61	1,30	1,13
55	-10	594	404	2,71	1,47	1,27
55	-5	723	435	2,81	1,66	1,44
55	0	871	465	2,91	1,87	1,62
55	5	1.038	493	3,01	2,11	1,82
55	7,2	1.118	504	3,05	2,22	1,91
55	10	1.224	519	3,11	2,36	2,04

60	-15	441	384	2,64	1,15	0,99
60	-10	544	421	2,76	1,29	1,12
60	-5	667	456	2,88	1,46	1,26
60	0	809	490	3,00	1,65	1,43
60	5	969	522	3,12	1,86	1,61
60	7,2	1.046	535	3,17	1,95	1,69
60	10	1.148	552	3,23	2,08	1,80

EN12900

X	Cooling Capacity (W)	Consumption (W)	Current (A)	Mass Flow (kg/h)
1	1.566,1136511538	196,6454224456	1,9677121379	13,543454418283
2	46,4154554895	-3,2668816741	-0,0165145100	0,41804819292993
3	-13,0659025925	5,1050339464	0,0179390433	-0,030989607409424
4	0,3721345621	-0,0321385969	-0,0000062370	0,0062648689354861
5	-0,2845970063	0,1686887546	0,0006879973	0,00068806582337139

Equation	$x_1 + x_2Te + x_3Tc + x_4Te^2 + x_5TeTc$
----------	---

COMPRESSOR DIMENSIONS

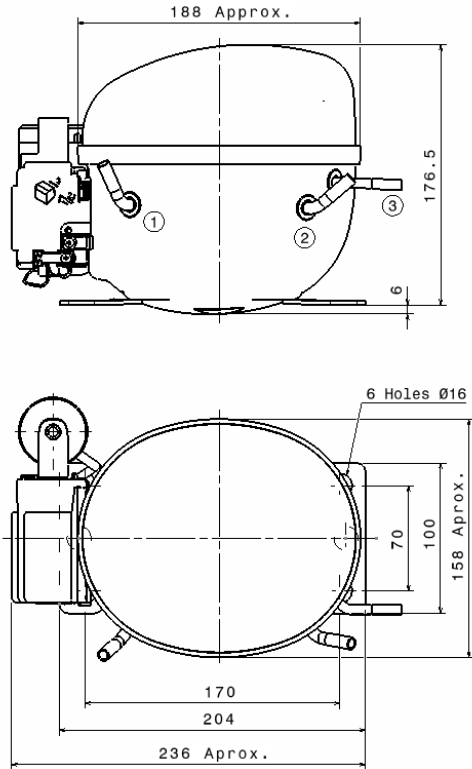

DESIGNATION INTERNAL DIAM.

DESIGNATION	INTERNAL DIAM.
1	Service 6,2 mm
2	Suction 6,2 mm
3	Discharge 4,9 mm

WIRING DIAGRAMS AND ELECTRICAL ASSEMBLY

CSIR CONNECTION (U range)

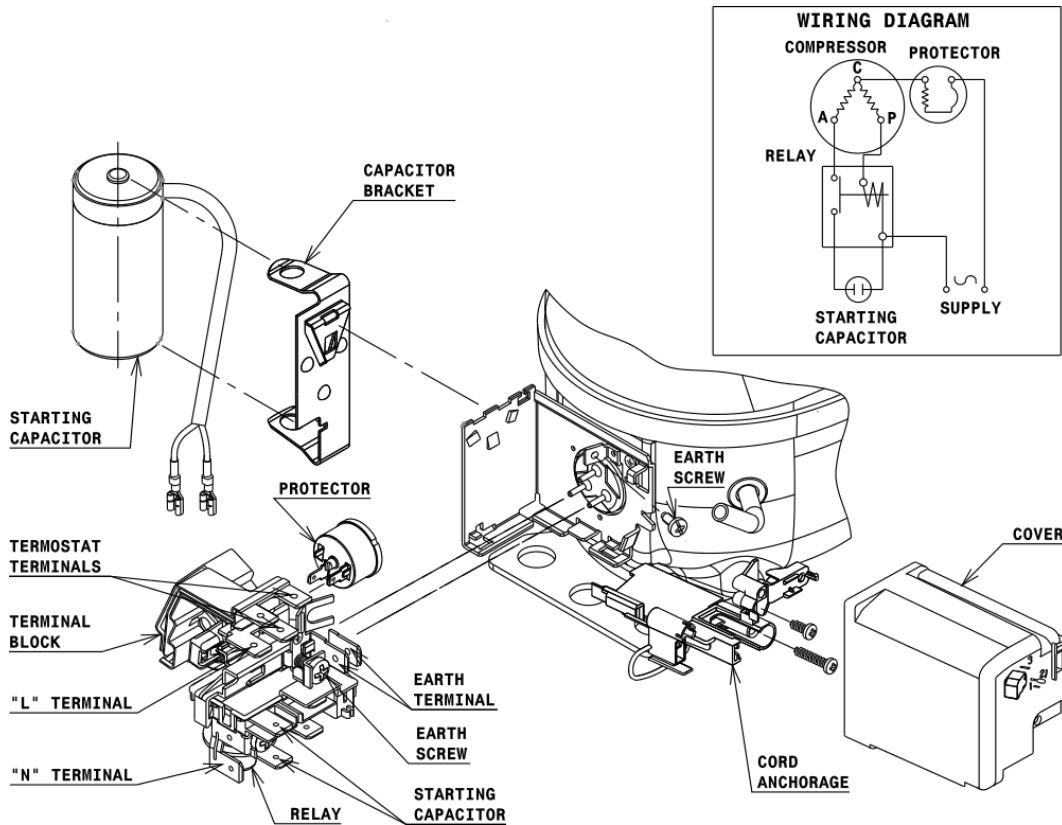

FIXINGS

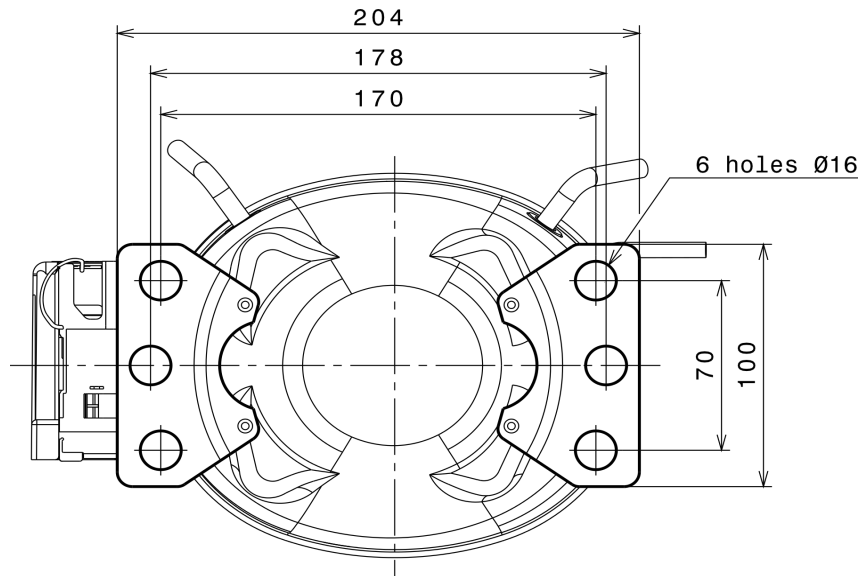

SILENT BLOCKS (MOUNTING ACCESSORIES)

STANDARD

$\varnothing 16$ holes (170x70 net)

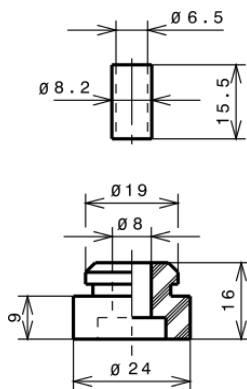

SNAP-ON

$\varnothing 16$ holes (170x70 net)

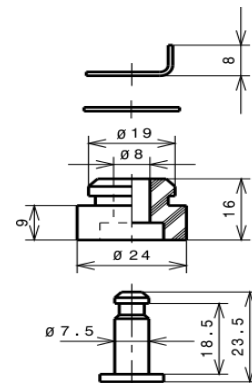

SOA

SOA R290 HBP

